

Bellow Boot Order Form

Internal Use Only:
Project #:

Fax completed form to: (216) 941-1130 or e-mail to: protect@nsamfg.com

Quotation Only Order Date of Order: Date Requested:
 Is this bellows boot a/an? OEM Replacement

I. Customer Information:

Contact Name: Title:
 Company Name: Customer Number:
 Telephone: Fax:
 Billing Address:
 Street Address: City/State: Zip:
 Shipping Address (if different from billing address):
 Street Address: City/State: Zip:

II. Equipment: Type: Others:
 Orientation:
 Rod Diameter:

III. Bellow Specifications (refer to diagram)

- | | | | |
|----|---------------------|-----|----|
| A. | Cuff ID (left) | in. | mm |
| B. | Cuff Length (left) | in. | mm |
| C. | Boot OD* | in. | mm |
| D. | Boot ID | in. | mm |
| E. | Cuff ID (right) | in. | mm |
| F. | Cuff Length (right) | in. | mm |
| G. | Max. Length | in. | mm |
| H. | Min. Length | in. | mm |

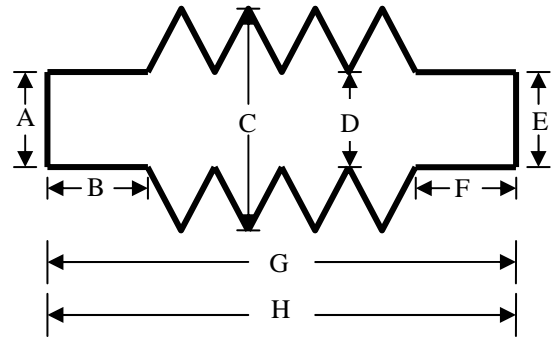

* - for lower price specify largest possible Boot OD

